

Document downloaded from the institutional repository of the University of Alcalá: <http://dspace.uah.es/dspace/>

This is a postprint version of the following published document:

Angulo-Vinuesa, X., Martín-Lopez, S., Nuño, J., Corredera, P., Ania-Castañón, J.D., Thévenaz, L., Gonzalez-Herraez, M., 2011, " Hot spot detection over 100 km with 2 meter resolution in a Raman-assisted Brillouin distributed sensor". Proc. SPIE 7753, 21st International Conference on Optical Fiber Sensors, 775309

Available at <http://dx.doi.org/10.1117/12.885041>

Copyright 2011 Society of Photo Optical Instrumentation Engineers. One print or electronic copy may be made for personal use only. Systematic electronic or print reproduction and distribution, duplication of any material in this paper for a fee or for commercial purposes, or modification of the content of the paper are prohibited.

*(Article begins on next page)*



This work is licensed under a  
Creative Commons Attribution-NonCommercial-  
NoDerivatives 4.0 International License.

# Hot spot detection over 100 km with 2 meter resolution in a Raman-assisted Brillouin distributed sensor

Xabier Angulo-Vinuesa<sup>1</sup>, Sonia Martin-Lopez<sup>1</sup>, Javier Nuño<sup>1</sup>, Pedro Corredera<sup>1</sup>,  
Juan Diego Ania-Castañón<sup>1</sup>, Luc Thévenaz<sup>2</sup>, Miguel Gonzalez-Herraez<sup>3</sup>

<sup>1</sup> Instituto de Óptica, CSIC, C/ Serrano 121, 28006, Madrid, Spain.

<sup>2</sup> Inst. of Electrical Engineering, EPFL, STI-GR-SCI Station 11, CH-1015, Lausanne, Switzerland.

<sup>3</sup> Dept. de Electrónica, Universidad de Alcalá, C. Universitario, 28871, Alcalá de Henares, Spain.

## ABSTRACT

We have developed a long-range Brillouin distributed sensor featuring 100 km measuring distance with 2 meter resolution. To our knowledge, this is the first time that a high-resolution setup reaches the barrier of 100 km measurement range. The key improvements with respect to previous configurations are explained.

**Keywords:** Brillouin scattering, distributed optic fiber sensor, Raman scattering, temperature sensor.

## 1. INTRODUCTION

Brillouin Optical Time-Domain Analysis (BOTDA) allows distributed detection of temperature and strain along the fiber. The BOTDA was first proposed by Horiguchi and Tateda<sup>[1], [2]</sup> in the late 80s, and since then has evolved into a consolidated fiber sensing technology. The underlying physical phenomenon in this technology is a nonlinear optical effect called Stimulated Brillouin Scattering (SBS)<sup>[3]</sup>. This effect is an acousto-optic process which manifests as a narrowband amplification of a counter-propagating probe beam when an intense coherent pump light beam is introduced through one end of a single-mode fiber. If the source light is centered at  $f_0$  frequency, the amplification of the counter-propagating beam occurs at a narrow spectral range around  $f_0 - \nu_B$ .  $\nu_B$  is known as the Brillouin shift of the fiber. In BOTDA, localization is achieved by pulsing the pump wave and analyzing the detected probe wave variations as a function of the time-of-flight of the pump pulse in the fiber. The resolution of the system is thus limited by the pump pulse width. The measurement process relies in mapping the variations of  $\nu_B$  along the fiber, which depends on the fiber properties as:

$$\nu_B = \left( \frac{2n\nu_a}{\lambda} \right) \quad (1)$$

where  $n$  is the refractive index of the fiber,  $\nu_a$  is the acoustic velocity along the fiber and  $\lambda$  is the source wavelength. Thus, BOTDA systems can in principle measure all the physical parameters that modify the refractive index or the acoustic velocity of the fiber, being strain and temperature the most effective ones. Two of the most restrictive features of these systems are the measurement range and the spatial resolution. Generally, the measuring distance is limited to 20-30 km, with 1-2 meter resolution<sup>[4]</sup>. The measurement range is limited by the fiber attenuation, which is approximately 0.2 dB/km in conventional fibers operating at 1550 nm. This attenuation causes a decay of both pump and signal powers as the distance grows, as well as an increase in the measurement uncertainty since the pump power is reduced with distance. At the same time, the resolution is set by the length of the pulses used to produce the Brillouin effect. Obviously, the objective is to acquire the highest possible resolution, but this requires the use of short optical pulses, which reduces both the effective distance for amplification and the amplification factor, while it increases the measurement uncertainty due to the associated spectral broadening of the interaction. Thus, generally, increasing the resolution strongly limits the measurement range. One may think that this problem can be circumvented by rising the pump power. However this approach is limited because pump depletion and other competing nonlinear effects become increasingly important. It is necessary then to find a proper balance between the length of the pulses and the required system specifications; short pulses for higher resolution or longer pulses for increased range. Several studies have proved that the fiber losses can be successfully compensated using distributed Raman amplification<sup>[5],[6],[7]</sup>, since it maintains the pump power to a level that guarantees a sufficient gain all over the fiber. This allows to have long-range systems with high resolution. In this work we present a first-order Raman assisted BOTDA sensor that features 100 km dynamic range

with only 2 meter resolution. We explain some key improvements in the experimental set up reported in<sup>[6]</sup> that allow us to achieve this enhanced performance.

## 2. EXPERIMENTAL SETUP

The experimental setup used for our purpose is very similar to the one depicted in a previously published work by some of the authors of this paper<sup>[6]</sup>, except that a couple of improvements have been implemented. A 4 mW Laser Diode (LD) (1 MHz linewidth), which emits at 1553.59 nm, provides the master signal to our BOTDA (Fig. 1). The pump and probe signals are obtained from this unique source, after being split and modulated<sup>[8]</sup>. The advantage of this technique is that any frequency disturbance in the master laser does not affect the frequency difference between the pump and probe signals. The pump is pulsed with pulses slightly longer than 20 ns. Since the measurement distance is 100 km, the repetition rate of the pulses has to be lower than 1 ms, which means that a very low duty cycle is used (in the order of  $10^{-5}$ ). This means that extinction ratios in the pulse in the order of  $10^5$  have to be achieved to correctly measure the probe wave variations. In this case, in order to achieve the necessary extinction ratio, two cascaded systems are used. First, in the modulator, an electronic proportional-integrator circuit is employed to set the working point of the modulator to minimum transmission. This allows to achieve easily extinction ratios of 25-35 dB. To arrive to 50 dB or more, a Non-linear Optical Loop Mirror (NOLM) is used after the pulse shaping and amplification. This is a key improvement in comparison with the system described in<sup>[6]</sup>. If correctly tuned, the NOLM triples the extinction ratio of the pulses. The NOLM also has the effect of a small compression of the pulses obtaining a pedestal-free narrow pulse<sup>[10],[9]</sup>. The system is tuned so that the pulse length entering the fiber is 20 ns and the repetition rate of the pulses is 700 Hz.

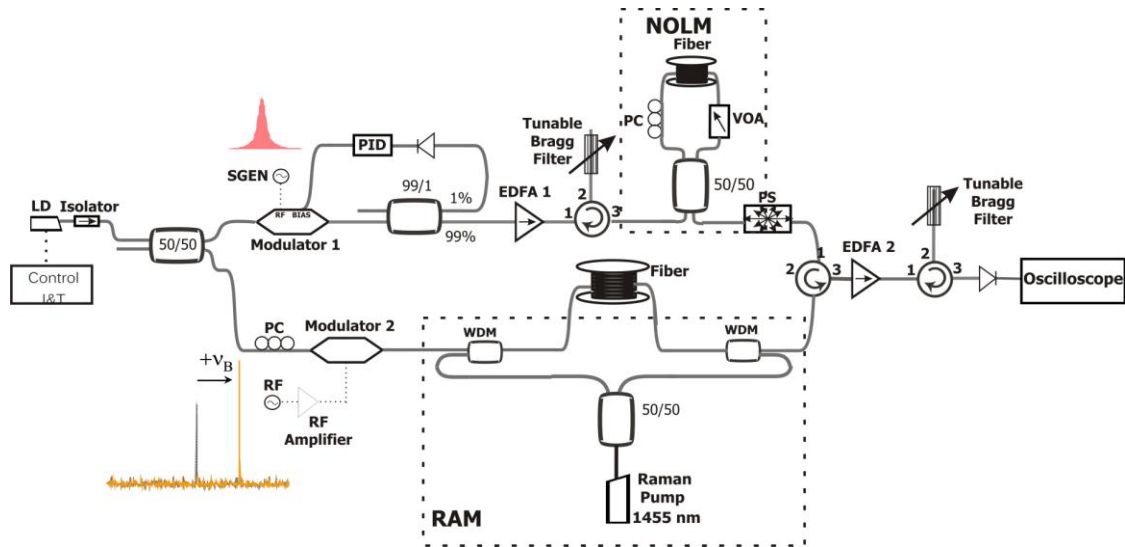

Fig. 1. Experimental setup of the Raman-assisted distributed Brillouin sensor. LD: Laser Diode; PC: Polarization controller; SGEN: Pulse generator; PID: Proportional-Integral electronic circuit; EDFA: Erbium Doped Fiber Amplifier; RF: Radio-Frequency generator; NOLM: Non-linear Optical Loop Mirror; PS: Polarization Scrambler; WDM: Wavelength Division Multiplexer.

The pump and probe signals are introduced in the sensing fiber in opposite directions in order to achieve SBS. A Raman Fiber Laser (RFL) is introduced through both fiber ends to generate a distributed amplification of the pump and probe signals along the fiber<sup>[11],[12],[13]</sup>. The BOTDA signals and Raman pumps are introduced in the fiber through Wavelength Division Multiplexers (WDM). The RFL emits at 1455 nm, so as to generate Raman amplification in the 1550 nm region. The maximum power of the RFL can reach 2.4 W, although we only used 480 mW (240 mW through each side). This Raman pump power is below the value needed for a perfect end-to-end compensation of the losses (so generally lower than the pump levels used in<sup>[6]</sup>), however it guarantees the best trade-off between amplification and RIN transfer for our RFL in this fiber segment. Before detection the probe signal is amplified and filtered by another EDFA and a grating.

## 3. RESULTS

In this section we illustrate the results obtained with the Raman-assisted BOTDA configuration described above as well as calculated results obtained with an analytical model developed previously<sup>[6]</sup>. Fig. 2 shows the typical gain trace obtained with this system. In this case the 100 km fiber segment is composed of four spools of 25 km of single mode

fiber (SMF), with an effective area of  $70 \mu\text{m}^2$ . The Brillouin frequency shift of the four fibers is approximately similar and located at approximately 10.65 GHz. The pump and probe power levels employed to achieve the results were 2.133 mW and  $0.17 \mu\text{W}$  respectively with 480 mW of Raman pump. Superimposed we can also see the expected theoretical gain trace obtained with the model developed in<sup>[6]</sup>. A good agreement can be found between the simulated and measured values. This verifies that the analytical model obtained in<sup>[6]</sup> can be considered suitable to analyze this system.

In Fig. 3, a representation of the full frequency sweep obtained for this fiber can be seen. It is noticeable that the gain as a function of the frequency fits the expected Gaussian/Lorentzian profile<sup>[3]</sup>. No depletion is visible in the pump pulse. The maximum gain contrast is achieved at approximately 10 km while the minimum gain contrast is obtained around 80 km. From here onwards, the gain contrast keeps increasing until the end of the fiber. As stated, around the 75-80 km the gain contrast is minimum. This is the point that has to be tested in order to verify the minimum performance of the setup in terms of resolution.

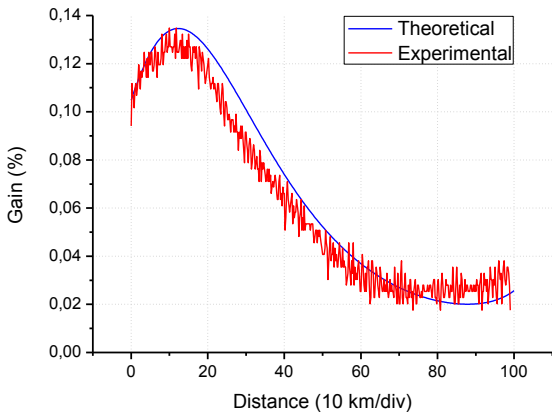

Fig. 2. Comparison between the obtained maximum gain trace at each position (red line) and the calculated results for a bidirectional Raman configuration.

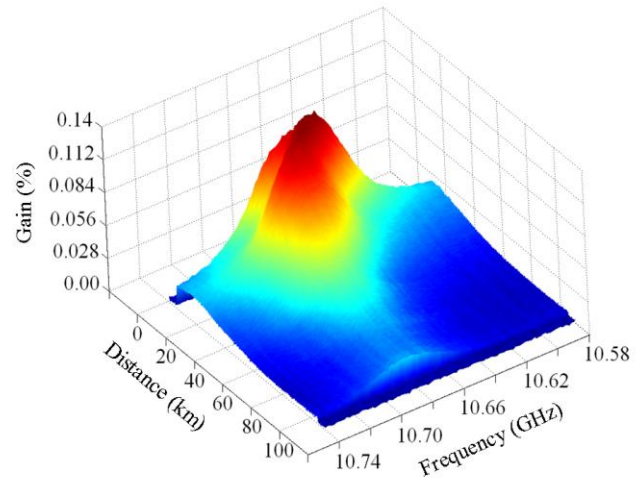

Fig. 3. Full gain trace of the fiber sensor that illustrates the complete measuring distance, 100 km.

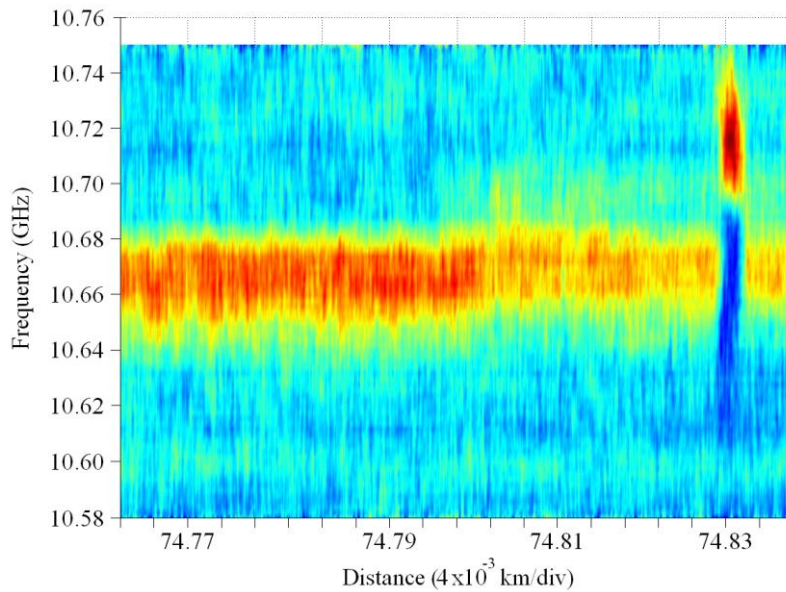

Fig. 4. Trace of the hot spot around the 75 km for a frequency sweep between 10.58 GHz and 10.75 GHz.

To demonstrate that our BOTDA is accurate, even in the worst conditions, we decided to locate our hot spot at that point. 2 meters of fiber were introduced in a water bath at  $55^\circ\text{C} (\pm 5^\circ\text{C})$ , with a room temperature of  $20^\circ\text{C}$ . Fig. 4 shows the

frequency sweep performed around the hot-spot location. We can clearly see the hot spot location at the expected position (roughly 74.83 km). We can also observe the transition between the third and fourth fiber spool at approximately 74.80 km. The frequency difference between the hot spot and the rest of the fiber sections is approximately 45 MHz. The relationship between the temperature and the Brillouin frequency shift is around 1.3 MHz/°C, which gives us a temperature variation of 35°C, value that totally agrees with the expected temperature difference.

#### 4. CONCLUSION

In conclusion, we have presented a distributed optical fiber sensor with 2 meter resolution and 100 km dynamic range. We have shown that the system works nicely as a temperature sensor with the previous features. This is the first time that such a long sensing distance with such small resolution is accomplished.

In comparison with our previous configuration, we have achieved a dynamic range extension of 25 km keeping the same resolution. This was achieved using lower pump, probe and Raman power levels compared to<sup>[6]</sup> and a much better extinction ratio in the pump pulse. The quality of the results makes us believe that it could be possible to achieve longer measuring distances applying higher power levels with more precise settings and lower RIN pumps.

#### ACKNOWLEDGEMENT

We acknowledge the support from the Spanish Ministry of Education and Science through projects TEC2008-5791, TEC2009-14423-C02-01 and TEC2009-14423-C02-02, the Ministerio de Fomento through project MIFFO (FOM-07/77) and the Comunidad de Madrid through project FACTOTEM2. Sonia Martin-Lopez and Javier Nuño acknowledge funding from the Ministerio de Ciencia e Innovación through a “Juan de la Cierva” contract and FPI fellowship, respectively. Xavier Angulo-Vinuesa acknowledges financial support from ICYF, S.A.

#### REFERENCES

- [1] Horiguchi, T. and Tateda, M., “Optical-fiber-attenuation investigation using stimulated Brillouin scattering between a pulse and a continuous wave,” *Opt. Lett.*, 14 (8), 408-410 (1989).
- [2] Horiguchi, T. and Tateda, M., “BOTDA – Nondestructive Measurement of Single-Mode Optical Fiber Attenuation Characteristics Using Brillouin Interaction: Theory,” *IEEE J. Lightwave Technol.*, 7 (8), 1170-1176 (1989).
- [3] Agrawal, G. P., [Nonlinear Fiber Optics – Fourth Edition], Academic Press, San Diego, 9, (2007).
- [4] Niklés, M., “Fibre optic distributed scattering sensing system: Perspectives and challenges for high performance applications,” Third European Workshop on Optical Fiber Sensors, 66190D, Italy, 2007.
- [5] Alahbadi, M. N., Cho, Y. T. and Newson, T. P., “150-km-range distributed temperature sensor based on coherent detection of spontaneous Brillouin backscatter and in-line Raman amplification,” *J. OSA B*, 22 (6), 1321-1324 (2005).
- [6] Rodríguez-Barrios, F., Martín-López, S., Carrasco-Sanz, A., Corredera, P., Ania-Castañón, J.D., Thévenaz, L. and González-Herráez, M., “Distributed Brillouin Fiber Sensor Assisted by First-Order Raman Amplification,” *IEEE J. Lightwave Technol.*, 28 (15), 2162-2172 (2010).
- [7] Martin-Lopez, S., Alcon-Camas, M., Rodriguez, F., Corredera, P., Ania-Castañón, J.D., Thévenaz, L. and Gonzalez-Herraez, M., “Brillouin optical time-domain analysis assisted by second-order Raman amplification”, *Opt Express*, 18 (18), 18769-18778 (2010).
- [8] Niklés, M., Thévenaz, L. and Robert, P. A., “Brillouin gain spectrum characterization in single-mode optical fibers,” *IEEE J. Lightwave Technol.*, 15 (10), 1842-1851 (1997).
- [9] Doran, N. J. and Wood, D., “Nonlinear-optical loop mirror,” *Opt. Lett.*, 13 (1), 56-58 (1988).
- [10] Wu, J., Li, Y., Lou, C. and Gao, Y., “Optimization of pulse compression with an unbalanced nonlinear optic mirror,” *Opt. Comm.*, 18, 43-47 (2000).
- [11] Stolen, R.H. and Ippen, E. P., “Raman gain in glass optical waveguides,” *App. Phys. Lett.*, 22, 276-278 (1972).
- [12] Ania-Castañón, J. D., Turitsyn, S. K. and Chernikov, S., “Raman Amplifiers: Distributed Raman amplification speeds communication,” *Laser Focus World*, (2006).
- [13] Bromage, J., “Raman Amplification for Fiber Communications Systems”, *IEEE J. Lightwave Technol.*, 22, 79-93 (2004).